



RFID safety switch with tumbler, plastic, quiescent current principle, tumbler monitoring, 24 V DC, with auxiliary release, IP69, locking force 1150 N, individually encoded multiple teach-in, coding high according to ISO 14119, diagnostics output M12 plug 8-pole, 3 LEDs for display of the operating states, 3 directions of actuation, latching force with turnstile adjustable: 25 N or 50 N, hygienic design, actuator 3SE6410-1AC01 to be ordered separately

product brand name	SIRIUS
product category	Non-contact safety switch
product designation	RFID safety switch with tumbler
design of the product	rectangular sensor unit
product type designation	3SE64
<b>Product Function</b>	
product function	
• positive opening	No
• control function for downstream devices	No
• cross-circuit/short-circuit recognition	Yes
suitability for use	
• safety-related circuits	Yes
<b>General technical data</b>	
product feature	individually coded, programmable several times, catch 25N/50N
product feature suitable for series connection	Yes
locking force	1 500 N
• according to EN ISO 14119	1 150 N
design of the RFID coding	individually coded, multiple teach-in capability
insulation voltage rated value	32 V
degree of pollution according to EN 60664-1	3
overvoltage category	Class III
surge voltage resistance rated value	0.8 kV
no-load current rated value	100 mA
protection class IP	IP66 in accordance with EN 60529 IP67 in accordance with EN 60529 IP69 in accordance with EN 60529
shock resistance	
• according to IEC 60068-2-27	30g / 11 ms
vibration resistance according to IEC 60068-2-6	10 ... 150 Hz, amplitude 0.35 mm
switching frequency	0.5 Hz
mechanical service life (operating cycles) typical	1 000 000
• note	when used as door stop: $\geq 50,000$ switching cycles (door masses $\leq 5$ kg and actuating speed $\leq 0.5$ m/s)
relative ON period [%] of magnet coil	100 %
reference code according to IEC 81346-2	B
Substance Prohibitance (Date)	07/01/2006
Weight	0.6 kg
<b>Sensor</b>	
height of the sensor	35 mm
length of the sensor	120 mm

<b>width of the sensor</b>	87.5 mm
<b>Ambient conditions</b>	
installation altitude at height above sea level maximum	2 000 m
<b>ambient temperature</b>	
• during operation	0 ... 60 °C
• during storage and transport	-10 ... +90 °C
<b>operating resource protection class according to IEC 61140</b>	III
relative humidity during operation maximum	93 %
• note	non-condensing, non-icing
<b>Control circuit/ Control</b>	
<b>current consumption of magnet coil rated value</b>	100 mA
<b>locked-rotor current peak of magnet coil</b>	250 mA
<b>duration of locked-rotor current peak</b>	200 ms
<b>Main circuit</b>	
operating voltage rated value	24 V
<b>operational current rated value</b>	250 mA
<b>Enclosure</b>	
<b>design of the housing</b>	special design
<b>material of the enclosure</b>	plastic, fiberglass reinforced thermoplast, self-extinguishing
<b>Actuator</b>	
• Product equipment auxiliary release of guard locking	Yes
• product feature latching	Yes
<b>locking mechanism design</b>	quiescent current principle
<b>detent force adjustable 1</b>	25 N
<b>detent force adjustable 2</b>	50 N
<b>angular offset between guard locking and actuator maximum</b>	2°
<b>Display</b>	
<b>product function status display</b>	Yes
display version as status display by LED	3 LEDs
<b>Contact</b>	
<b>circuit principle</b>	spring-actuated lock (closed-circuit principle)
<b>operating distance</b>	2 mm
<b>assured operating distance OFF</b>	20 mm
<b>assured operating distance ON</b>	1 mm
<b>Installation/ mounting/ dimensions</b>	
<b>fastening method</b>	screw fixing
<b>design of the thread of the screw for securing the equipment</b>	2x M6
<b>tightening torque of fixing screw minimum</b>	6 N·m
<b>tightening torque of fixing screw maximum</b>	7 N·m
<b>Connections/ Terminals</b>	
<b>type of electrical connection</b>	M12 plug, 8-pole, A-coded
<b>wire length maximum</b>	200 m
<b>contact assignment</b>	
• of socket 1 at PIN 1	A1 supply voltage Ub
• of socket 1 at PIN 2	X1 safety input 1
• of socket 1 at PIN 3	A2 GND
• of socket 1 at PIN 4	OSSD1 safety output 1
• of socket 1 at PIN 5	OUT diagnostic output
• of the bushing 1 at PIN 6	X2 safety input 2
• of the bushing 1 at PIN 7	OSSD2 safety output 2
• of the bushing 1 at PIN 8	IN magnet controller
<b>Supply voltage</b>	
<b>type of voltage of the supply voltage</b>	DC
<b>supply voltage rated value</b>	24 V
<b>supply voltage</b>	26.4 ... 20.4 V
<b>fuse protection type for external auxiliary power supply</b>	2 A gG

<b>required</b>	
<b>Inputs/ Outputs</b>	
<b>input voltage at digital input</b>	
• with signal <0> at DC	-3 ... +5 V
• for signal <1> at DC	15 ... 30
<b>input voltage at safety-related digital input</b>	
• for signal <0> at DC	-3 ... +5 V
• for signal <1> at DC	15 ... 30 V
input current at digital input for signal <1> typical	10 mA
<b>input current at safety-related digital input for signal &lt;1&gt; typical</b>	5 mA
<b>number of semiconductor outputs</b>	
• for signaling function	1
• safety-related	2
<b>design of the contactless switching element safety-related</b>	short-circuit proof, sourcing output
<b>type of diagnostic output</b>	short-circuit proof, sourcing output
<b>dark period at safety-related digital output maximum</b>	0.5 ms
<b>dark period test duration</b>	
• at digital input maximum	5 ms
• at safety-related digital input maximum	1 ms
<b>dark period test interval</b>	
• at digital input minimum	40 ms
• at safety-related digital input minimum	100 ms
• at safety-related digital output maximum	1 000 ms
residual current at digital output with signal <0> maximum	0.5 mA
<b>voltage drop</b>	
• at safety-related output maximum	2 V
• at diagnostic output maximum	2 V
<b>output current minimum</b>	0.5 mA
<b>output current at safety-related output maximum</b>	0.25 A
<b>output current at diagnostic output maximum</b>	0.05 A
<b>Communication/ Protocol</b>	
design of the interface for safety-related communication	connector M12
<b>transmission frequency rated value</b>	125 kHz
<b>Safety related data</b>	
product function suitable for safety function	Yes
category according to EN 954-1	4
<b>IEC 62061</b>	
<b>Safety Integrity Level (SIL)</b>	
• for position monitoring according to IEC 62061	3
• for guard locking according to IEC 62061	2
<b>PFHD with high demand rate</b>	
• for position monitoring according to IEC 62061	5.2E-9 1/h
• for guard locking according to IEC 62061	2E-9 1/h
<b>ISO 13849</b>	
performance level (PL) according to EN ISO 13849-1	e
category according to EN ISO 13849-1	4
<b>performance level (PL)</b>	
• for position monitoring according to ISO 13849-1	e
• for guard locking according to ISO 13849-1	d
<b>category</b>	
• for position monitoring according to ISO 13849-1	4
• for guard locking according to ISO 13849-1	2
<b>IEC 61508</b>	
Safety Integrity Level (SIL) according to IEC 61508	3
<b>PFDavg with low demand rate</b>	
• for position monitoring according to IEC 62061	4.5E-4
• for guard locking according to IEC 62061	0.0018
<b>T1 value for proof test interval or service life</b>	

<ul style="list-style-type: none"> <li>• for position monitoring according to IEC 61508</li> <li>• for guard locking according to IEC 61508</li> </ul>	20 a 20 a
<b>type of monitoring</b>	guard locking
<b>response delay maximum</b>	5 000 ms
<b>OFF-delay time with safety-related request</b>	
<ul style="list-style-type: none"> <li>• when switched off via control inputs maximum</li> <li>• for safety-related shutdown via actuator maximum</li> </ul>	1.5 ms 100 ms
conditional short-circuit current (I <sub>q</sub> ) at 400 V according to IEC 60947-4-1 rated value	100 A

Approvals Certificates		
General Product Approval	EMV	Functional Safety



[Type Examination Certificate](#)

other	Environment
-------	-------------



[Confirmation](#)

[Environmental Confirmations](#)

### Further information

Information on the packaging

<https://support.industry.siemens.com/cs/ww/en/view/109813875>

Information for data generation and storage

<https://support.industry.siemens.com/cs/ww/en/view/109995012>

Information- and Downloadcenter (Catalogs, Brochures,...)

<https://www.siemens.com/ic10>

Industry Mall (Online ordering system)

<https://mall.industry.siemens.com/mall/en/en/Catalog/product?mlfb=3SE6415-1BB02>

Cax online generator

<https://support.automation.siemens.com/WW/CAXorder/default.aspx?lang=en&mlfb=3SE6415-1BB02>

Service&Support (Manuals, Certificates, Characteristics, FAQs,...)

<https://support.industry.siemens.com/cs/ww/en/ps/3SE6415-1BB02>

Image database (product images, 2D dimension drawings, 3D models, device circuit diagrams, EPLAN macros, ...)

[https://www.automation.siemens.com/bilddb/cax\\_de.aspx?mlfb=3SE6415-1BB02&lang=en](https://www.automation.siemens.com/bilddb/cax_de.aspx?mlfb=3SE6415-1BB02&lang=en)

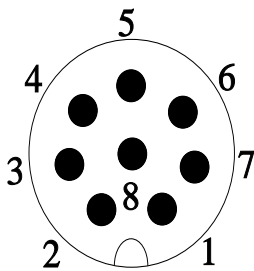
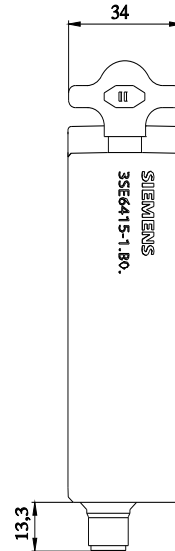
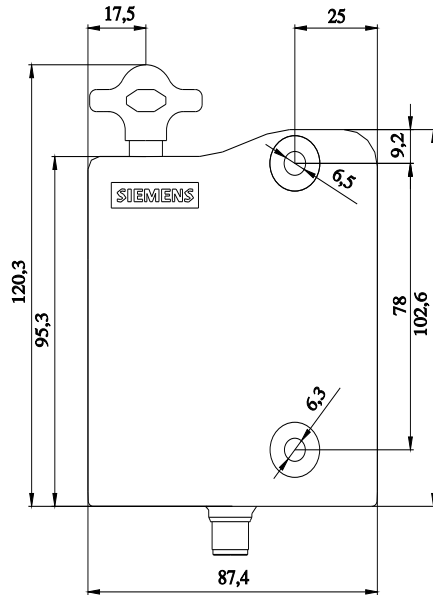
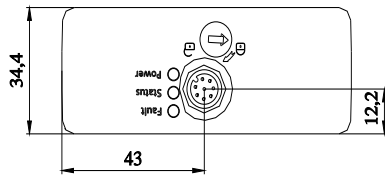

1	WH = White	→	A1	supply voltage U <sub>e</sub>
2	BN = Brown	→	X1	safety input 1
3	GN = Green	→	A2	GND
4	YE = Yellow	→	OSSD1	safety output 1
5	GY = Grey	→	OUT	diagnostics output
6	PK = Pink	→	X2	safety input 2
7	BU = Blue	→	OSSD2	safety output 2
8	RD = Red	→	IN	solenoid control

