

Siemens
EcoTech



Circuit breaker size S3 for motor protection, Class 20 A-release 36...50 A N-release 650 A screw terminal Increased switching capacity 100 kA



product brand name	SIRIUS
product designation	Circuit breaker
design of the product	For motor protection
product type designation	3RV2
General technical data	
size of the circuit-breaker	S3
size of contactor can be combined company-specific	S3
product extension auxiliary switch	Yes
power loss [W] for rated value of the current	
• at AC in hot operating state	27 W
• at AC in hot operating state per pole	9 W
insulation voltage with degree of pollution 3 at AC rated value	1 000 V
surge voltage resistance rated value	8 kV
shock resistance according to IEC 60068-2-27	25g / 11 ms Sinus
mechanical service life (operating cycles)	
• of the main contacts typical	25 000
• of auxiliary contacts typical	25 000
electrical endurance (operating cycles) typical	25 000
reference code according to IEC 81346-2	Q
Substance Prohibitance (Date)	03/01/2017
SVHC substance name	Lead - 7439-92-1
Weight	2.229 kg
Ambient conditions	
installation altitude at height above sea level maximum	2 000 m
ambient temperature	
• during operation	-20 ... +60 °C
• during storage	-50 ... +80 °C
• during transport	-50 ... +80 °C
relative humidity during operation	10 ... 95 %
Environmental footprint	
Environmental Product Declaration (EPD)	Yes
global warming potential [CO2 eq] total	283.24 kg
global warming potential [CO2 eq] during manufacturing	18.5 kg
global warming potential [CO2 eq] during sales	1.24 kg
global warming potential [CO2 eq] during operation	265 kg
global warming potential [CO2 eq] after end of life	-1.5 kg
Siemens Eco Profile (SEP)	Siemens EcoTech

Main circuit	
number of poles for main current circuit	3
adjustable current response value current of the current-dependent overload release	36 ... 50 A
type of voltage for main current circuit	AC
operating voltage <ul style="list-style-type: none"> • rated value • at AC-3 rated value maximum • at AC-3e rated value maximum 	20 ... 690 V 690 V 690 V
operating frequency rated value	50 ... 60 Hz
operational current rated value	50 A
operational current <ul style="list-style-type: none"> • at AC-3 at 400 V rated value • at AC-3e at 400 V rated value 	50 A 50 A
operating power <ul style="list-style-type: none"> • at AC-3 <ul style="list-style-type: none"> — at 230 V rated value — at 400 V rated value — at 500 V rated value — at 690 V rated value • at AC-3e <ul style="list-style-type: none"> — at 230 V rated value — at 400 V rated value — at 500 V rated value — at 690 V rated value 	11 kW 22 kW 30 kW 45 kW 11 kW 22 kW 30 kW 45 kW
operating frequency <ul style="list-style-type: none"> • at AC-3 maximum • at AC-3e maximum 	15 1/h 15 1/h
Auxiliary circuit	
type of voltage for auxiliary and control circuit	AC/DC
number of NC contacts for auxiliary contacts	0
number of NO contacts for auxiliary contacts	0
number of CO contacts for auxiliary contacts	0
Protective and monitoring functions	
product function <ul style="list-style-type: none"> • ground fault detection • phase failure detection 	No Yes
trip class	CLASS 20
design of the overload release	thermal
maximum short-circuit current breaking capacity (Icu) <ul style="list-style-type: none"> • at AC at 240 V rated value • at AC at 400 V rated value • at AC at 500 V rated value • at AC at 690 V rated value 	100 kA 100 kA 15 kA 10 kA
operating short-circuit current breaking capacity (Ics) at AC <ul style="list-style-type: none"> • at 240 V rated value • at 400 V rated value • at 500 V rated value • at 690 V rated value 	100 kA 50 kA 7.5 kA 5 kA
response value current of instantaneous short-circuit trip unit	650 A
UL/CSA ratings	
full-load current (FLA) for 3-phase AC motor <ul style="list-style-type: none"> • at 480 V rated value • at 600 V rated value 	50 A 50 A
yielded mechanical performance [hp] <ul style="list-style-type: none"> • for single-phase AC motor <ul style="list-style-type: none"> — at 110/120 V rated value — at 230 V rated value • for 3-phase AC motor <ul style="list-style-type: none"> — at 200/208 V rated value — at 220/230 V rated value 	5 hp 10 hp 15 hp 20 hp

— at 460/480 V rated value	40 hp
— at 575/600 V rated value	50 hp

Short-circuit protection

product function short circuit protection	Yes
design of the short-circuit trip	magnetic

Installation/ mounting/ dimensions

mounting position	any
fastening method	screw and snap-on mounting onto 35 mm DIN rail according to DIN EN 60715
height	165 mm
width	70 mm
depth	176 mm
required spacing	
<ul style="list-style-type: none"> ● with side-by-side mounting at the side ● for grounded parts at 400 V <ul style="list-style-type: none"> — downwards — upwards — at the side ● for live parts at 400 V <ul style="list-style-type: none"> — downwards — upwards — at the side ● for grounded parts at 500 V <ul style="list-style-type: none"> — downwards — upwards — at the side ● for live parts at 500 V <ul style="list-style-type: none"> — downwards — upwards — at the side ● for grounded parts at 690 V <ul style="list-style-type: none"> — downwards — upwards — at the side ● for live parts at 690 V <ul style="list-style-type: none"> — downwards — upwards — at the side 	0 mm 70 mm 70 mm 10 mm 70 mm 70 mm 10 mm 110 mm 110 mm 10 mm 110 mm 110 mm 10 mm 150 mm 150 mm 30 mm 150 mm 150 mm 30 mm

Connections/ Terminals

type of electrical connection	
<ul style="list-style-type: none"> ● for main current circuit 	screw-type terminals
arrangement of electrical connectors for main current circuit	Top and bottom
type of connectable conductor cross-sections	
<ul style="list-style-type: none"> ● for main contacts <ul style="list-style-type: none"> — solid — solid or stranded — finely stranded with core end processing — finely stranded without core end processing 	2x (2.5 ... 16 mm ²) 2x (2.5 ... 50 mm ²), 1x (10 ... 70 mm ²) 2x (2.5 ... 35 mm ²), 1x (2.5 ... 50 mm ²) 2x (10 ... 35 mm ²), 1x (10 ... 50 mm ²)
tightening torque	
<ul style="list-style-type: none"> ● for main contacts for ring cable lug 	4.5 ... 6 N·m
outer diameter of the usable ring cable lug maximum	19 mm
tightening torque	
<ul style="list-style-type: none"> ● for main contacts with screw-type terminals 	4.5 ... 6 N·m

Safety related data

product function suitable for safety function	Yes
suitability for use	
<ul style="list-style-type: none"> ● safety-related switching on ● safety-related switching OFF 	No Yes
service life maximum	10 a
test wear-related service life necessary	Yes
proportion of dangerous failures	

<ul style="list-style-type: none"> with low demand rate according to SN 31920 with high demand rate according to SN 31920 	40 % 50 %
B10 value with high demand rate according to SN 31920	5 000
failure rate [FIT] with low demand rate according to SN 31920	50 FIT
ISO 13849	
device type according to ISO 13849-1	3
overdimensioning according to ISO 13849-2 necessary	Yes
IEC 61508	
safety device type according to IEC 61508-2	Type A
T1 value	
<ul style="list-style-type: none"> for proof test interval or service life according to IEC 61508 	10 a
Electrical Safety	
protection class IP on the front according to IEC 60529	IP20
touch protection on the front according to IEC 60529	finger-safe, for vertical contact from the front
Display	
display version for switching status	Handle

Approvals Certificates

General Product Approval



KC



General Product Approval	Test Certificates	Maritime application
---------------------------------	--------------------------	-----------------------------



[Special Test Certificate](#)

[Type Test Certificates/Test Report](#)



Maritime application	other
-----------------------------	--------------



[Confirmation](#)

[Miscellaneous](#)



other	Railway	Environment
--------------	----------------	--------------------



[Special Test Certificate](#)



[Environmental Confirmations](#)

Further information

- Information on the packaging
<https://support.industry.siemens.com/cs/ww/en/view/109813875>
- Information for data generation and storage
<https://support.industry.siemens.com/cs/ww/en/view/109995012>
- Information- and Downloadcenter (Catalogs, Brochures,...)
<https://www.siemens.com/ic10>
- Industry Mall (Online ordering system)
<https://mall.industry.siemens.com/mall/en/en/Catalog/product?mlfb=3RV2042-4HB10>
- Cax online generator
<https://support.automation.siemens.com/WW/CAXorder/default.aspx?lang=en&mlfb=3RV2042-4HB10>
- Service&Support (Manuals, Certificates, Characteristics, FAQs,...)
<https://support.industry.siemens.com/cs/ww/en/ps/3RV2042-4HB10>
- Image database (product images, 2D dimension drawings, 3D models, device circuit diagrams, EPLAN macros, ...)
https://www.automation.siemens.com/bilddb/cax_de.aspx?mlfb=3RV2042-4HB10&lang=en
- Characteristic: Tripping characteristics, I_t, Let-through current
<https://support.industry.siemens.com/cs/ww/en/ps/3RV2042-4HB10/char>

Further characteristics (e.g. electrical endurance, switching frequency)

<https://www.automation.siemens.com/bilddb/index.aspx?view=Search&mlfb=3RV2042-4HB10&objecttype=14&gridview=view1>

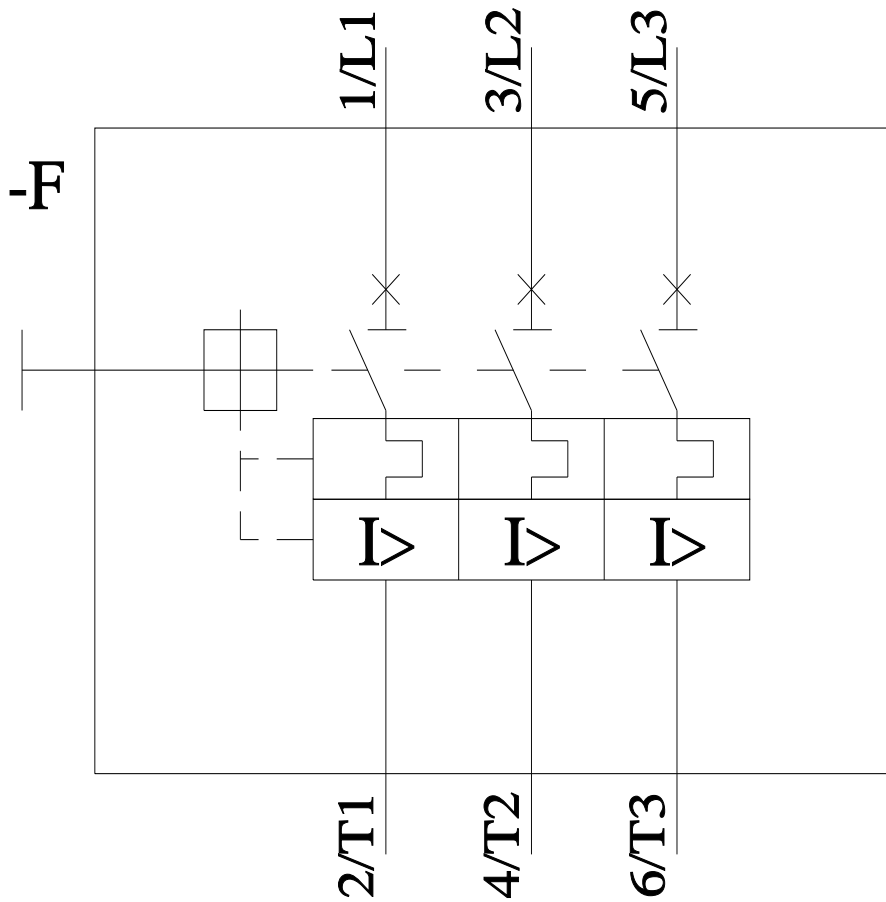
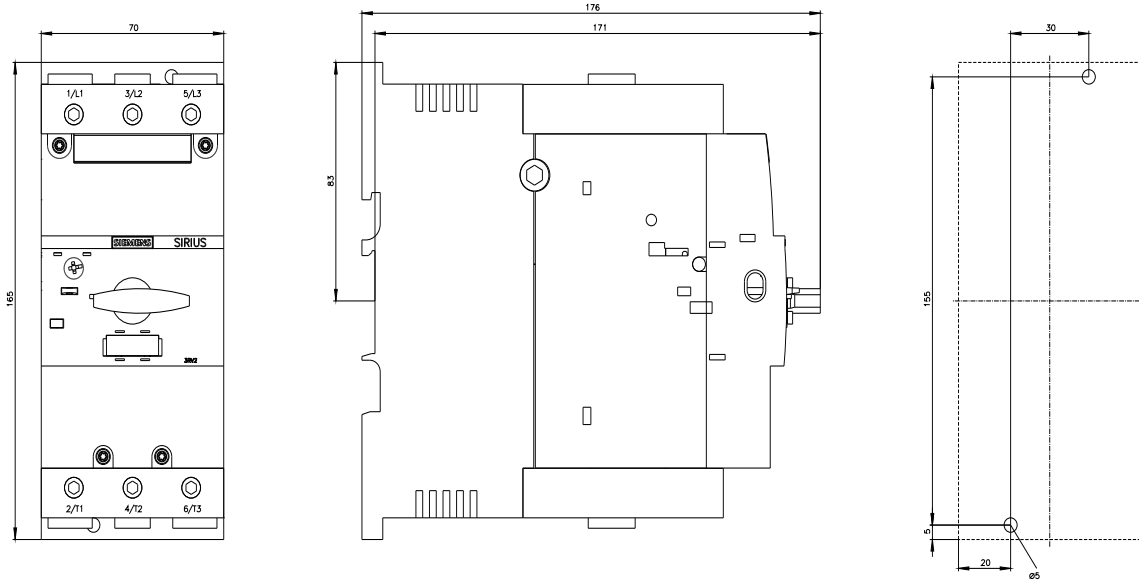

last modified:

11/11/2025 