

Siemens  
EcoTech



Circuit breaker size S3 for system protection without phase failure protection A-release 80...100 A N-release 1300 A screw terminal Standard switching capacity



product brand name	SIRIUS
product designation	Circuit breaker
design of the product	for system protection
product type designation	3RV2
<b>General technical data</b>	
size of the circuit-breaker	S3
size of contactor can be combined company-specific	S3
product extension auxiliary switch	Yes
power loss [W] for rated value of the current	
• at AC in hot operating state	44 W
• at AC in hot operating state per pole	14.7 W
insulation voltage with degree of pollution 3 at AC rated value	1 000 V
surge voltage resistance rated value	8 kV
shock resistance according to IEC 60068-2-27	25g / 11 ms Sinus
mechanical service life (operating cycles)	
• of the main contacts typical	25 000
• of auxiliary contacts typical	25 000
electrical endurance (operating cycles) typical	25 000
reference code according to IEC 81346-2	Q
Substance Prohibitance (Date)	03/01/2017
SVHC substance name	Lead - 7439-92-1
Weight	2.264 kg
<b>Ambient conditions</b>	
installation altitude at height above sea level maximum	2 000 m
ambient temperature	
• during operation	-20 ... +60 °C
• during storage	-50 ... +80 °C
• during transport	-50 ... +80 °C
relative humidity during operation	10 ... 95 %
<b>Environmental footprint</b>	
Environmental Product Declaration (EPD)	Yes
global warming potential [CO <sub>2</sub> eq] total	283.24 kg
global warming potential [CO <sub>2</sub> eq] during manufacturing	18.5 kg
global warming potential [CO <sub>2</sub> eq] during sales	1.24 kg
global warming potential [CO <sub>2</sub> eq] during operation	265 kg
global warming potential [CO <sub>2</sub> eq] after end of life	-1.5 kg

Siemens Eco Profile (SEP)	Siemens EcoTech
<b>Main circuit</b>	
number of poles for main current circuit	3
adjustable current response value current of the current-dependent overload release	80 ... 100 A
type of voltage for main current circuit	AC
operating voltage <ul style="list-style-type: none"> <li>• rated value</li> <li>• at AC-3 rated value maximum</li> <li>• at AC-3e rated value maximum</li> </ul>	20 ... 690 V 690 V 690 V
operating frequency rated value	50 ... 60 Hz
operational current rated value	100 A
operational current <ul style="list-style-type: none"> <li>• at AC-3 at 400 V rated value</li> <li>• at AC-3e at 400 V rated value</li> </ul>	100 A 100 A
operating power <ul style="list-style-type: none"> <li>• at AC-3 <ul style="list-style-type: none"> <li>— at 230 V rated value</li> <li>— at 400 V rated value</li> <li>— at 500 V rated value</li> <li>— at 690 V rated value</li> </ul> </li> <li>• at AC-3e <ul style="list-style-type: none"> <li>— at 230 V rated value</li> <li>— at 400 V rated value</li> <li>— at 500 V rated value</li> <li>— at 690 V rated value</li> </ul> </li> </ul>	30 kW 45 kW 55 kW 90 kW 30 kW 45 kW 55 kW 90 kW
operating frequency <ul style="list-style-type: none"> <li>• at AC-3 maximum</li> <li>• at AC-3e maximum</li> </ul>	15 1/h 15 1/h
<b>Auxiliary circuit</b>	
type of voltage for auxiliary and control circuit	AC/DC
number of NC contacts for auxiliary contacts	0
number of NO contacts for auxiliary contacts	0
number of CO contacts for auxiliary contacts	0
<b>Protective and monitoring functions</b>	
product function <ul style="list-style-type: none"> <li>• ground fault detection</li> <li>• phase failure detection</li> </ul>	No No
trip class	CLASS 10
design of the overload release	thermal
maximum short-circuit current breaking capacity (I <sub>cu</sub> ) <ul style="list-style-type: none"> <li>• at AC at 240 V rated value</li> <li>• at AC at 400 V rated value</li> <li>• at AC at 500 V rated value</li> <li>• at AC at 690 V rated value</li> </ul>	100 kA 65 kA 8 kA 5 kA
operating short-circuit current breaking capacity (I <sub>cs</sub> ) at AC <ul style="list-style-type: none"> <li>• at 400 V rated value</li> <li>• at 500 V rated value</li> <li>• at 690 V rated value</li> </ul>	30 kA 4 kA 3 kA
response value current of instantaneous short-circuit trip unit	1 300 A
<b>Short-circuit protection</b>	
product function short circuit protection	Yes
design of the short-circuit trip	magnetic
design of the fuse link for IT network for short-circuit protection of the main circuit <ul style="list-style-type: none"> <li>• at 240 V</li> <li>• at 400 V</li> <li>• at 500 V</li> <li>• at 690 V</li> </ul>	gG 160 A gG 125 A gG 100 A gG 100 A

**Installation/ mounting/ dimensions**

<b>mounting position</b>	any
<b>fastening method</b>	screw and snap-on mounting onto 35 mm DIN rail according to DIN EN 60715
<b>height</b>	165 mm
<b>width</b>	70 mm
<b>depth</b>	176 mm
<b>required spacing</b>	
<ul style="list-style-type: none"> <li>● with side-by-side mounting at the side</li> </ul>	0 mm
<ul style="list-style-type: none"> <li>● for grounded parts at 400 V <ul style="list-style-type: none"> <li>— downwards</li> <li>— upwards</li> <li>— at the side</li> </ul> </li> </ul>	70 mm 70 mm 10 mm
<ul style="list-style-type: none"> <li>● for live parts at 400 V <ul style="list-style-type: none"> <li>— downwards</li> <li>— upwards</li> <li>— at the side</li> </ul> </li> </ul>	70 mm 70 mm 10 mm
<ul style="list-style-type: none"> <li>● for grounded parts at 500 V <ul style="list-style-type: none"> <li>— downwards</li> <li>— upwards</li> <li>— at the side</li> </ul> </li> </ul>	110 mm 110 mm 10 mm
<ul style="list-style-type: none"> <li>● for live parts at 500 V <ul style="list-style-type: none"> <li>— downwards</li> <li>— upwards</li> <li>— at the side</li> </ul> </li> </ul>	110 mm 110 mm 10 mm
<ul style="list-style-type: none"> <li>● for grounded parts at 690 V <ul style="list-style-type: none"> <li>— downwards</li> <li>— upwards</li> <li>— at the side</li> </ul> </li> </ul>	150 mm 150 mm 30 mm
<ul style="list-style-type: none"> <li>● for live parts at 690 V <ul style="list-style-type: none"> <li>— downwards</li> <li>— upwards</li> <li>— at the side</li> </ul> </li> </ul>	150 mm 150 mm 30 mm

**Connections/ Terminals**

<b>type of electrical connection</b>	
<ul style="list-style-type: none"> <li>● for main current circuit</li> </ul>	screw-type terminals
<b>arrangement of electrical connectors for main current circuit</b>	Top and bottom
<b>type of connectable conductor cross-sections</b>	
<ul style="list-style-type: none"> <li>● for main contacts <ul style="list-style-type: none"> <li>— solid</li> <li>— solid or stranded</li> <li>— finely stranded with core end processing</li> <li>— finely stranded without core end processing</li> </ul> </li> </ul>	2x (2.5 ... 16 mm <sup>2</sup> ) 2x (2,5 ... 50 mm <sup>2</sup> ), 1x (10 ... 70 mm <sup>2</sup> ) 2x (2.5 ... 35 mm <sup>2</sup> ), 1x (2.5 ... 50 mm <sup>2</sup> ) 2x (10 ... 35 mm <sup>2</sup> ), 1x (10 ... 50 mm <sup>2</sup> )
<b>tightening torque</b>	
<ul style="list-style-type: none"> <li>● for main contacts for ring cable lug</li> </ul>	4.5 ... 6 N·m
<b>outer diameter of the usable ring cable lug maximum</b>	19 mm
<b>tightening torque</b>	
<ul style="list-style-type: none"> <li>● for main contacts with screw-type terminals</li> </ul>	4.5 ... 6 N·m
<b>design of the thread of the connection screw</b>	
<ul style="list-style-type: none"> <li>● for main contacts</li> </ul>	M8

**Safety related data**

product function suitable for safety function	Yes
<b>suitability for use</b>	
<ul style="list-style-type: none"> <li>● safety-related switching on</li> <li>● safety-related switching OFF</li> </ul>	No Yes
<b>service life maximum</b>	10 a
<b>test wear-related service life necessary</b>	Yes
<b>proportion of dangerous failures</b>	
<ul style="list-style-type: none"> <li>● with low demand rate according to SN 31920</li> </ul>	40 %

• with high demand rate according to SN 31920	50 %
<b>B10 value with high demand rate according to SN 31920</b>	5 000
<b>failure rate [FIT] with low demand rate according to SN 31920</b>	50 FIT
<b>ISO 13849</b>	
<b>device type according to ISO 13849-1</b>	3
<b>overdimensioning according to ISO 13849-2 necessary</b>	Yes
<b>IEC 61508</b>	
<b>safety device type according to IEC 61508-2</b>	Type A
<b>T1 value</b>	10 a
• for proof test interval or service life according to IEC 61508	
<b>Electrical Safety</b>	
<b>protection class IP on the front according to IEC 60529</b>	IP20
<b>touch protection on the front according to IEC 60529</b>	finger-safe, for vertical contact from the front
<b>Display</b>	
display version for switching status	Handle
<b>Approvals Certificates</b>	
<b>General Product Approval</b>	



[KC](#)



**Test Certificates**

**Maritime application**

[Special Test Certificate](#)

[Type Test Certificates/Test Report](#)



**Maritime application**

**other**



[Miscellaneous](#)



[Confirmation](#)



**Railway**

**Environment**

[Special Test Certificate](#)

[Confirmation](#)



Siemens EcoTech



[Environmental Confirmations](#)

**Further information**

Information on the packaging

<https://support.industry.siemens.com/cs/ww/en/view/109813875>

Information for data generation and storage

<https://support.industry.siemens.com/cs/ww/en/view/109995012>

Information- and Downloadcenter (Catalogs, Brochures,...)

<https://www.siemens.com/ic10>

Industry Mall (Online ordering system)

<https://mall.industry.siemens.com/mall/en/en/Catalog/product?mlfb=3RV2041-4MA10-0DA0>

Cax online generator

<https://support.automation.siemens.com/WW/CAXorder/default.aspx?lang=en&mlfb=3RV2041-4MA10-0DA0>

Service&Support (Manuals, Certificates, Characteristics, FAQs,...)

<https://support.industry.siemens.com/cs/ww/en/ps/3RV2041-4MA10-0DA0>

Image database (product images, 2D dimension drawings, 3D models, device circuit diagrams, EPLAN macros, ...)

[https://www.automation.siemens.com/bilddb/cax\\_de.aspx?mlfb=3RV2041-4MA10-0DA0&lang=en](https://www.automation.siemens.com/bilddb/cax_de.aspx?mlfb=3RV2041-4MA10-0DA0&lang=en)

Characteristic: Tripping characteristics, I<sup>2</sup>t, Let-through current

<https://support.industry.siemens.com/cs/ww/en/ps/3RV2041-4MA10-0DA0/char>

Further characteristics (e.g. electrical endurance, switching frequency)

<https://www.automation.siemens.com/bilddb/index.aspx?view=Search&mlfb=3RV2041-4MA10-0DA0&objecttype=14&gridview=view1>

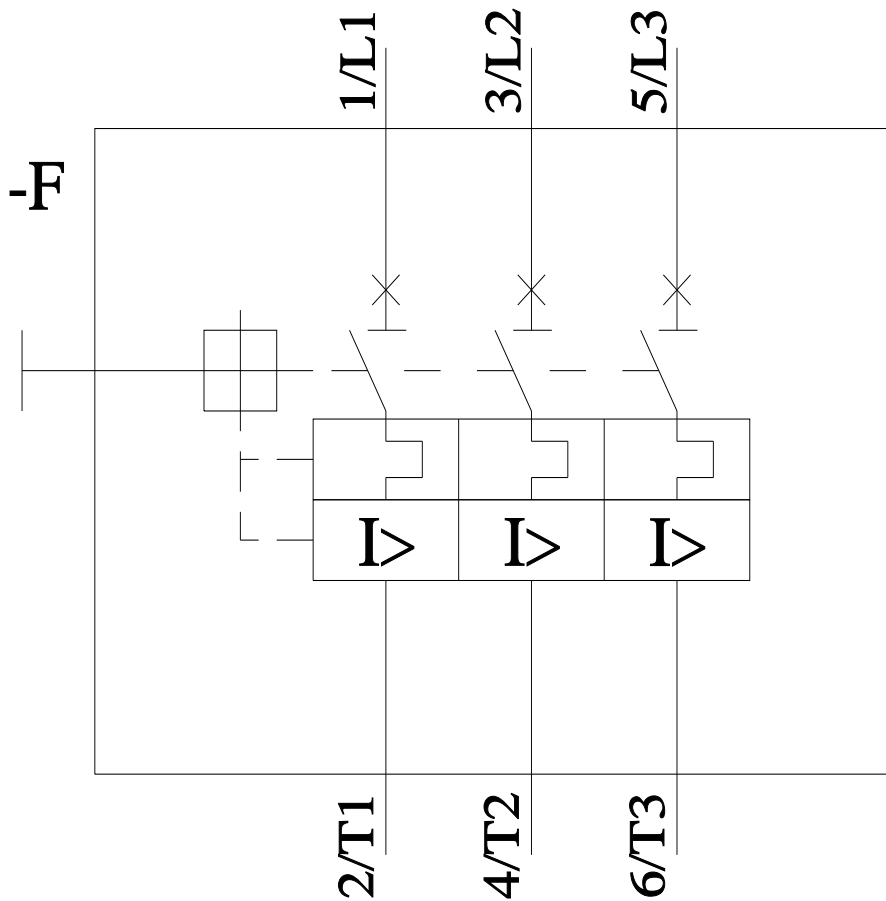
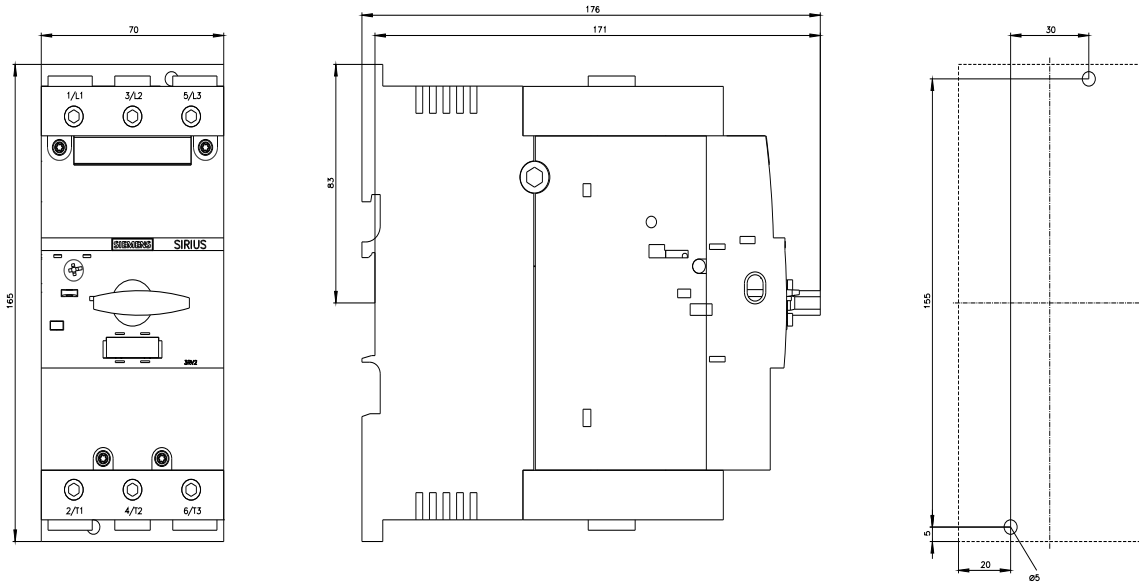

---

last modified:

11/11/2025 