



power contactor, AC-3, 16 A, 7.5 kW / 400 V, 4-pole, 60 V DC, main contacts: 2 NO + 2 NC, screw terminal, size: S00

product brand name	SIRIUS
product designation	contactor
product type designation	3RT25
General technical data	
size of contactor	S00
product extension	
• function module for communication	No
• auxiliary switch	Yes
power loss [W] for rated value of the current	
• at AC in hot operating state per pole	1 W
• without load current share typical	4 W
type of calculation of power loss depending on pole	quadratic
insulation voltage	
• of main circuit with degree of pollution 3 rated value	690 V
• of auxiliary circuit with degree of pollution 3 rated value	690 V
surge voltage resistance	
• of main circuit rated value	6 kV
• of auxiliary circuit rated value	6 kV
maximum permissible voltage for protective separation between coil and main contacts according to EN 60947-1	400 V
shock resistance at rectangular impulse	
• at DC	7.3g / 5 ms, 4.7g / 10 ms
shock resistance with sine pulse	
• at DC	11,4g / 5 ms, 7,3g / 10 ms
mechanical service life (operating cycles)	
• of contactor typical	30 000 000
• of the contactor with added electronically optimized auxiliary switch block typical	5 000 000
• of the contactor with added auxiliary switch block typical	10 000 000
reference code according to IEC 81346-2	Q
Substance Prohibitance (Date)	10/01/2009
Weight	0.295 kg
Ambient conditions	
installation altitude at height above sea level maximum	2 000 m
ambient temperature	
• during operation	-25 ... +60 °C
• during storage	-55 ... +80 °C
relative humidity minimum	10 %
relative humidity at 55 °C according to IEC 60068-2-30 maximum	95 %

Environmental footprint

Environmental Product Declaration(EPD)	Yes
global warming potential [CO2 eq] total	153 kg
global warming potential [CO2 eq] during manufacturing	1.42 kg
global warming potential [CO2 eq] during operation	152 kg
global warming potential [CO2 eq] after end of life	-0.305 kg

Main circuit

number of poles for main current circuit	4
number of NO contacts for main contacts	2
number of NC contacts for main contacts	2
operational current	
<ul style="list-style-type: none"> ● at AC-1 up to 690 V <ul style="list-style-type: none"> — at ambient temperature 40 °C rated value — at ambient temperature 60 °C rated value ● at AC-2 at AC-3 at 400 V <ul style="list-style-type: none"> — per NO contact rated value — per NC contact rated value 	<p>22 A</p> <p>20 A</p> <p>16 A</p> <p>9 A</p>
minimum cross-section in main circuit at maximum AC-1 rated value	4 mm ²
operational current	
<ul style="list-style-type: none"> ● at 1 current path at DC-1 <ul style="list-style-type: none"> — at 24 V rated value — at 110 V rated value — at 220 V rated value — at 440 V rated value ● with 2 current paths in series at DC-1 <ul style="list-style-type: none"> — at 24 V rated value — at 110 V rated value — at 220 V rated value — at 440 V rated value ● at 1 current path at DC-3 at DC-5 <ul style="list-style-type: none"> — at 24 V per NC contact rated value — at 24 V per NO contact rated value — at 110 V per NC contact rated value — at 110 V per NO contact rated value — at 220 V per NC contact rated value — at 220 V per NO contact rated value ● with 2 current paths in series at DC-3 at DC-5 <ul style="list-style-type: none"> — at 24 V per NC contact rated value — at 24 V per NO contact rated value — at 110 V per NC contact rated value — at 110 V per NO contact rated value 	<p>20 A</p> <p>2.1 A</p> <p>0.8 A</p> <p>0.6 A</p> <p>20 A</p> <p>12 A</p> <p>1.6 A</p> <p>0.8 A</p> <p>20 A</p> <p>20 A</p> <p>0.075 A</p> <p>0.15 A</p> <p>0.375 A</p> <p>0.75 A</p> <p>20 A</p> <p>20 A</p> <p>0.175 A</p> <p>0.35 A</p>
operating power at AC-2 at AC-3	
<ul style="list-style-type: none"> ● at 230 V per NC contact rated value ● at 230 V per NO contact rated value ● at 400 V per NC contact rated value ● at 400 V per NO contact rated value 	<p>2.2 kW</p> <p>4 kW</p> <p>4 kW</p> <p>7.5 kW</p>
short-time withstand current in cold operating state up to 40 °C	
<ul style="list-style-type: none"> ● limited to 1 s switching at zero current maximum ● limited to 5 s switching at zero current maximum ● limited to 10 s switching at zero current maximum ● limited to 30 s switching at zero current maximum ● limited to 60 s switching at zero current maximum 	<p>165 A; Use minimum cross-section acc. to AC-1 rated value</p> <p>165 A; Use minimum cross-section acc. to AC-1 rated value</p> <p>128 A; Use minimum cross-section acc. to AC-1 rated value</p> <p>92 A; Use minimum cross-section acc. to AC-1 rated value</p> <p>74 A; Use minimum cross-section acc. to AC-1 rated value</p>
power loss [W] at AC-3 at 400 V for rated value of the operational current per conductor	1 W
power loss [W] at AC-3e at 400 V for rated value of the operational current per conductor	1 W
no-load switching frequency	
<ul style="list-style-type: none"> ● at AC 	10 000 1/h

• at DC	10 000 1/h
operating frequency	
• at AC-1 maximum	1 000 1/h
Control circuit/ Control	
type of voltage of the control supply voltage	DC
control supply voltage at DC rated value	60 V
operating range factor control supply voltage rated value of magnet coil at DC	
• initial value	0.8
• full-scale value	1.1
closing power of magnet coil at DC	4 W
holding power of magnet coil at DC	4 W
closing delay	
• at DC	30 ... 100 ms
opening delay	
• at DC	7 ... 13 ms
arcing time	10 ... 15 ms
Auxiliary circuit	
number of NC contacts for auxiliary contacts instantaneous contact	0
number of NO contacts for auxiliary contacts instantaneous contact	0
operational current at AC-12 maximum	10 A
operational current at AC-15	
• at 230 V rated value	10 A
• at 400 V rated value	3 A
operational current at DC-12	
• at 48 V rated value	6 A
• at 60 V rated value	6 A
• at 110 V rated value	3 A
• at 125 V rated value	2 A
• at 220 V rated value	1 A
• at 600 V rated value	0.15 A
operational current at DC-13	
• at 24 V rated value	10 A
• at 48 V rated value	2 A
• at 60 V rated value	2 A
• at 110 V rated value	1 A
• at 220 V rated value	0.3 A
• at 600 V rated value	0.1 A
contact reliability of auxiliary contacts	1 faulty switching per 100 million (17 V, 1 mA)
UL/CSA ratings	
yielded mechanical performance [hp]	
• for single-phase AC motor at 230 V rated value	2 hp
• for 3-phase AC motor at 460/480 V rated value	5 hp
contact rating of auxiliary contacts according to UL	A600 / Q600
Short-circuit protection	
design of the fuse link	
• for short-circuit protection of the main circuit	
— with type of coordination 1 required	gG: 35 A (690 V, 100 kA)
— with type of coordination 2 required	gG: 20 A (690 V, 100 kA)
Installation/ mounting/ dimensions	
mounting position	+/-180° rotation possible on vertical mounting surface; can be tilted forward and backward by +/- 22.5° on vertical mounting surface
fastening method side-by-side mounting	Yes
fastening method	screw and snap-on mounting onto 35 mm DIN rail according to DIN EN 50022
height	57.5 mm
width	45 mm
depth	73 mm
required spacing	

- with side-by-side mounting
 - forwards 0 mm
 - backwards 0 mm
 - upwards 0 mm
 - downwards 0 mm
 - at the side 0 mm
- for grounded parts
 - forwards 0 mm
 - backwards 0 mm
 - upwards 0 mm
 - at the side 6 mm
 - downwards 0 mm
- for live parts
 - forwards 0 mm
 - backwards 0 mm
 - upwards 0 mm
 - downwards 0 mm
 - at the side 6 mm

0 mm
0 mm
0 mm
0 mm
0 mm
0 mm
0 mm
6 mm
0 mm
0 mm
0 mm
0 mm
0 mm
6 mm

Connections/ Terminals

type of electrical connection <ul style="list-style-type: none"> • for main current circuit • for auxiliary and control circuit • at contactor for auxiliary contacts • of magnet coil 	screw-type terminals screw-type terminals Screw-type terminals Screw-type terminals
type of connectable conductor cross-sections <ul style="list-style-type: none"> • for main contacts <ul style="list-style-type: none"> — solid — solid or stranded — finely stranded with core end processing • for AWG cables for main contacts 	2x (0.5 ... 1.5 mm ²), 2x (0.75 ... 2.5 mm ²), 2x 4 mm ² 2x (0,5 ... 1,5 mm ²), 2x (0,75 ... 2,5 mm ²), 2x 4 mm ² 2x (0.5 ... 1.5 mm ²), 2x (0.75 ... 2.5 mm ²) 2x (20 ... 16), 2x (18 ... 14), 2x 12
type of connectable conductor cross-sections <ul style="list-style-type: none"> • for auxiliary contacts <ul style="list-style-type: none"> — solid — solid or stranded — finely stranded with core end processing • for AWG cables for auxiliary contacts 	2x (0.5 ... 1.5 mm ²), 2x (0.75 ... 2.5 mm ²), 2x 4 mm ² 2x (0,5 ... 1,5 mm ²), 2x (0,75 ... 2,5 mm ²), 2x 4 mm ² 2x (0.5 ... 1.5 mm ²), 2x (0.75 ... 2.5 mm ²) 2x (20 ... 16), 2x (18 ... 14), 2x 12
AWG number as coded connectable conductor cross section for main contacts	20 ... 12
AWG number as coded connectable conductor cross section for auxiliary contacts	20 ... 12

Safety related data

product function <ul style="list-style-type: none"> • mirror contact according to IEC 60947-4-1 • positively driven operation according to IEC 60947-5-1 	Yes; with 3RH29 No
---	-----------------------

Electrical Safety

protection class IP on the front according to IEC 60529	IP20
touch protection on the front according to IEC 60529	finger-safe, for vertical contact from the front

Approvals Certificates

General Product Approval	EMV
---------------------------------	-----



Test Certificates	Maritime application
--------------------------	-----------------------------

[Special Test Certificate](#)

[Type Test Certificates/Test Report](#)



Maritime application

other



[Miscellaneous](#)



[Confirmation](#)

Railway

Dangerous goods

Environment

[Special Test Certificate](#)

[Transport Information](#)



[Environmental Confirmations](#)

Further information

Information on the packaging

<https://support.industry.siemens.com/cs/ww/en/view/109813875>

Information for data generation and storage

<https://support.industry.siemens.com/cs/ww/en/view/109995012>

Information- and Downloadcenter (Catalogs, Brochures,...)

<https://www.siemens.com/ic10>

Industry Mall (Online ordering system)

<https://mall.industry.siemens.com/mall/en/en/Catalog/product?mlfb=3RT2518-1BE40>

Cax online generator

<https://support.automation.siemens.com/WW/CAXorder/default.aspx?lang=en&mlfb=3RT2518-1BE40>

Service&Support (Manuals, Certificates, Characteristics, FAQs,...)

<https://support.industry.siemens.com/cs/ww/en/ps/3RT2518-1BE40>

Image database (product images, 2D dimension drawings, 3D models, device circuit diagrams, EPLAN macros, ...)

https://www.automation.siemens.com/bilddb/cax_de.aspx?mlfb=3RT2518-1BE40&lang=en

Characteristic: Tripping characteristics, I²t, Let-through current

<https://support.industry.siemens.com/cs/ww/en/ps/3RT2518-1BE40/char>

Further characteristics (e.g. electrical endurance, switching frequency)

<https://www.automation.siemens.com/bilddb/index.aspx?view=Search&mlfb=3RT2518-1BE40&objecttype=14&gridview=view1>

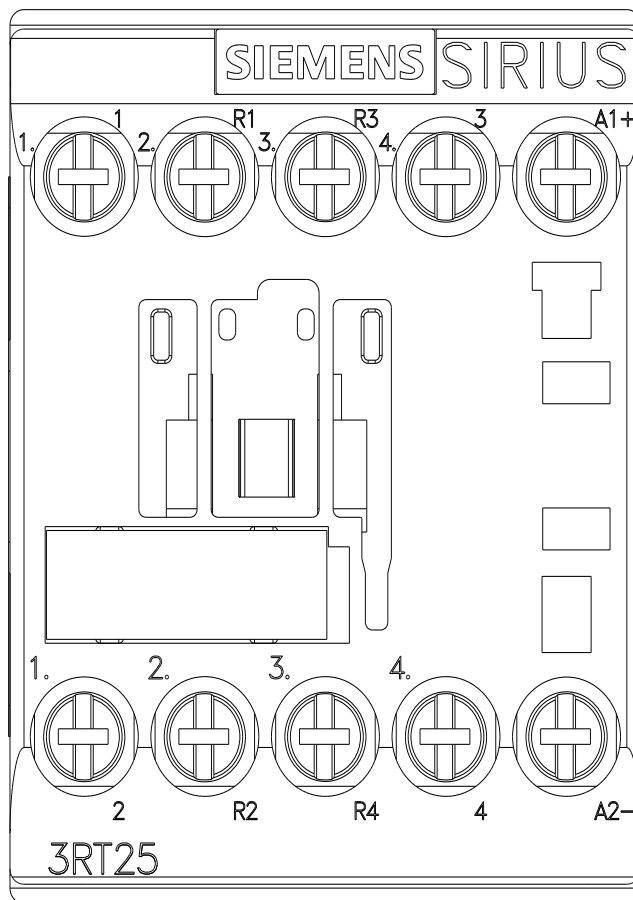
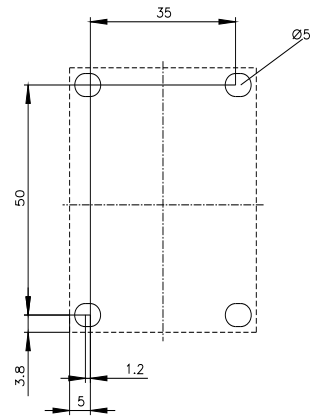
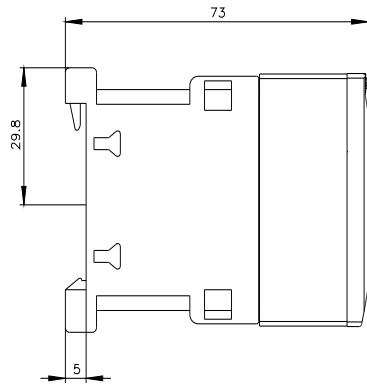
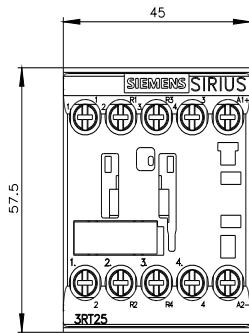



last modified:

11/11/2025 