



traction contactor, AC-3e/AC-3, 80 A, 37 kW / 400 V, 3-pole, 24 V DC, 0.7-1.25*
 Uc, solid-state operating mechanism, with integrated varistor, auxiliary contacts: 1
 NO + 1 NC, main circuit: screw terminal, control and auxiliary circuit: spring-loaded
 terminal, frame size: S2

product brand name	SIRIUS
product designation	Power contactor
design of the product	With extended operating range
product type designation	3RT2
General technical data	
size of contactor	S2
product extension	
• function module for communication	No
• auxiliary switch	Yes
power loss [W] for rated value of the current	
• at AC in hot operating state	17.1 W
• at AC in hot operating state per pole	5.7 W
type of calculation of power loss depending on pole	quadratic
insulation voltage	
• of main circuit with degree of pollution 3 rated value	690 V
• of auxiliary circuit with degree of pollution 3 rated value	690 V
surge voltage resistance	
• of main circuit rated value	6 kV
• of auxiliary circuit rated value	6 kV
maximum permissible voltage for protective separation between coil and main contacts according to EN 60947-1	400 V
shock resistance at rectangular impulse	
• at DC	7.7g / 5 ms, 4.5g / 10 ms
shock resistance with sine pulse	
• at DC	12g / 5 ms, 7g / 10 ms
mechanical service life (operating cycles)	
• of contactor typical	10 000 000
• of the contactor with added electronically optimized auxiliary switch block typical	5 000 000
• of the contactor with added auxiliary switch block typical	10 000 000
reference code according to IEC 81346-2	Q
Substance Prohibitance (Date)	10/01/2014
SVHC substance name	Lead - 7439-92-1 Lead monoxide (lead oxide) - 1317-36-8 2-methyl-1-(4-methylthiophenyl)-2-morpholinopropan-1-one - 71868-10-5 Melamine - 108-78-1
Weight	1.106 kg
Ambient conditions	
installation altitude at height above sea level maximum	2 000 m
ambient temperature	
• during operation	-40 ... +70 °C
• during storage	-55 ... +80 °C

relative humidity minimum	10 %
relative humidity at 55 °C according to IEC 60068-2-30 maximum	95 %
Environmental footprint	
Environmental Product Declaration(EPD)	Yes
global warming potential [CO2 eq] total	107 kg
global warming potential [CO2 eq] during manufacturing	5.88 kg
global warming potential [CO2 eq] during operation	102 kg
global warming potential [CO2 eq] after end of life	-0.988 kg
Main circuit	
number of poles for main current circuit	3
number of NO contacts for main contacts	3
operating voltage	
• at AC-3 rated value maximum	690 V
• at AC-3e rated value maximum	690 V
operational current	
• at AC-1 at 400 V at ambient temperature 40 °C rated value	90 A
• at AC-1	
— up to 690 V at ambient temperature 40 °C rated value	90 A
— up to 690 V at ambient temperature 60 °C rated value	80 A
• at AC-2 at 400 V rated value	80 A
• at AC-3	
— at 400 V rated value	80 A
— at 500 V rated value	80 A
— at 690 V rated value	58 A
• at AC-3e	
— at 400 V rated value	80 A
— at 500 V rated value	80 A
— at 690 V rated value	58 A
• at AC-4 at 400 V rated value	55 A
minimum cross-section in main circuit	
• at maximum AC-1 rated value	35 mm ²
• at maximum Ith rated value	35 mm ²
operational current for approx. 200000 operating cycles at AC-4	
• at 400 V rated value	30 A
• at 690 V rated value	24 A
operational current	
• at 1 current path at DC-1	
— at 24 V rated value	55 A
— at 110 V rated value	4.5 A
— at 220 V rated value	1 A
— at 440 V rated value	0.4 A
— at 600 V rated value	0.25 A
• with 2 current paths in series at DC-1	
— at 24 V rated value	55 A
— at 110 V rated value	45 A
— at 220 V rated value	5 A
— at 440 V rated value	1 A
— at 600 V rated value	0.8 A
• with 3 current paths in series at DC-1	
— at 24 V rated value	55 A
— at 110 V rated value	55 A
— at 220 V rated value	45 A
— at 440 V rated value	2.9 A
— at 600 V rated value	1.4 A
• at 1 current path at DC-3 at DC-5	
— at 24 V rated value	35 A
— at 110 V rated value	2.5 A

— at 220 V rated value	1 A
— at 440 V rated value	0.1 A
— at 600 V rated value	0.06 A
• with 2 current paths in series at DC-3 at DC-5	
— at 24 V rated value	55 A
— at 110 V rated value	25 A
— at 220 V rated value	5 A
— at 440 V rated value	0.27 A
— at 600 V rated value	0.16 A
• with 3 current paths in series at DC-3 at DC-5	
— at 24 V rated value	55 A
— at 110 V rated value	55 A
— at 220 V rated value	25 A
— at 440 V rated value	0.6 A
— at 600 V rated value	0.35 A
operating power	
• at AC-2 at 400 V rated value	37 kW
• at AC-3	
— at 230 V rated value	22 kW
— at 400 V rated value	37 kW
— at 500 V rated value	37 kW
— at 690 V rated value	45 kW
• at AC-3e	
— at 230 V rated value	22 kW
— at 400 V rated value	37 kW
— at 500 V rated value	37 kW
— at 690 V rated value	45 kW
operating power for approx. 200000 operating cycles at AC-4	
• at 400 V rated value	15.8 kW
• at 690 V rated value	21.8 kW
short-time withstand current in cold operating state up to 40 °C	
• limited to 1 s switching at zero current maximum	1 298 A; Use minimum cross-section acc. to AC-1 rated value
• limited to 5 s switching at zero current maximum	898 A; Use minimum cross-section acc. to AC-1 rated value
• limited to 10 s switching at zero current maximum	640 A; Use minimum cross-section acc. to AC-1 rated value
• limited to 30 s switching at zero current maximum	414 A; Use minimum cross-section acc. to AC-1 rated value
• limited to 60 s switching at zero current maximum	333 A; Use minimum cross-section acc. to AC-1 rated value
no-load switching frequency	
• at DC	1 500 1/h
operating frequency	
• at AC-2 at AC-3e maximum	350 1/h
• at AC-4 maximum	150 1/h
Ratings for railway applications	
thermal current (I_{th}) up to 690 V	
• up to 40 °C according to IEC 60077 rated value	90 A
• up to 70 °C according to IEC 60077 rated value	75 A
Control circuit/ Control	
type of voltage	DC
type of voltage of the control supply voltage	DC
control supply voltage at DC rated value	24 V
operating range factor control supply voltage rated value of magnet coil at DC	
• initial value	0.7
• full-scale value	1.25
design of the surge suppressor	with varistor
inrush current peak	3 A
duration of inrush current peak	50 μs
locked-rotor current mean value	1 A
locked-rotor current peak	2.6 A
duration of locked-rotor current	230 ms

holding current mean value	40 mA
closing power of magnet coil at DC	23 W
holding power of magnet coil at DC	1 W
closing delay	
• at DC	35 ... 110 ms
opening delay	
• at DC	30 ... 55 ms
arcing time	10 ... 20 ms
control version of the switch operating mechanism	Standard A1 - A2
Auxiliary circuit	
number of NC contacts for auxiliary contacts	1
• instantaneous contact	1
number of NO contacts for auxiliary contacts	1
• instantaneous contact	1
operational current at AC-12 maximum	10 A
operational current at AC-15	
• at 230 V rated value	10 A
• at 400 V rated value	3 A
• at 500 V rated value	2 A
• at 690 V rated value	1 A
operational current at DC-12	
• at 24 V rated value	10 A
• at 48 V rated value	6 A
• at 60 V rated value	6 A
• at 110 V rated value	3 A
• at 125 V rated value	2 A
• at 220 V rated value	1 A
• at 600 V rated value	0.15 A
operational current at DC-13	
• at 24 V rated value	10 A
• at 48 V rated value	2 A
• at 60 V rated value	2 A
• at 110 V rated value	1 A
• at 125 V rated value	0.9 A
• at 220 V rated value	0.3 A
• at 600 V rated value	0.1 A
UL/CSA ratings	
full-load current (FLA) for 3-phase AC motor	
• at 480 V rated value	65 A
• at 600 V rated value	62 A
yielded mechanical performance [hp]	
• for single-phase AC motor	
— at 110/120 V rated value	5 hp
— at 230 V rated value	15 hp
• for 3-phase AC motor	
— at 200/208 V rated value	20 hp
— at 220/230 V rated value	25 hp
— at 460/480 V rated value	50 hp
— at 575/600 V rated value	60 hp
contact rating of auxiliary contacts according to UL	A600 / P600
Short-circuit protection	
design of the miniature circuit breaker for short-circuit protection of the auxiliary circuit up to 230 V	C characteristic: 10 A; 0.4 kA
design of the fuse link	
• for short-circuit protection of the main circuit	
— with type of coordination 1 required	gG: 250 A (690 V, 100 kA), aM: 160 A (690 V, 100 kA), BS88: 200 A (415 V, 80 kA)
— with type of coordination 2 required	gG: 160 A (690 V, 100 kA), aM: 80 A (690 V, 100 kA), BS88: 125 A (415 V, 80 kA)
• for short-circuit protection of the auxiliary switch required	gG: 10 A (690 V, 1 kA)
Installation/ mounting/ dimensions	

mounting position	+/-180° rotation possible on vertical mounting surface; can be tilted forward and backward by +/- 22.5° on vertical mounting surface
fastening method side-by-side mounting	Yes
fastening method	screw and snap-on mounting onto 35 mm DIN rail according to DIN EN 60715
height	114 mm
width	55 mm
depth	130 mm
required spacing	
<ul style="list-style-type: none"> • with side-by-side mounting <ul style="list-style-type: none"> — forwards 10 mm — upwards 10 mm — downwards 10 mm — at the side 0 mm • for grounded parts <ul style="list-style-type: none"> — forwards 10 mm — upwards 10 mm — at the side 6 mm — downwards 10 mm • for live parts <ul style="list-style-type: none"> — forwards 10 mm — upwards 10 mm — downwards 10 mm — at the side 6 mm 	

Connections/ Terminals

type of electrical connection	
<ul style="list-style-type: none"> • for main current circuit • for auxiliary and control circuit • at contactor for auxiliary contacts • of magnet coil 	screw-type terminals spring-loaded terminals Spring-type terminals Spring-type terminals
type of connectable conductor cross-sections	
<ul style="list-style-type: none"> • for main contacts <ul style="list-style-type: none"> — solid or stranded 2x (1 ... 35 mm²), 1x (1 ... 50 mm²) — finely stranded with core end processing 2x (1 ... 25 mm²), 1x (1 ... 35 mm²) • for AWG cables for main contacts 2x (18 ... 2), 1x (18 ... 1) 	
type of connectable conductor cross-sections	
<ul style="list-style-type: none"> • for auxiliary contacts <ul style="list-style-type: none"> — solid or stranded 2x (0.5 ... 2.5 mm²) — finely stranded with core end processing 2x (0.5 ... 1.5 mm²) — finely stranded without core end processing 2x (0.5 ... 2.5 mm²) • for AWG cables for auxiliary contacts 2x (20 ... 14) 	
AWG number as coded connectable conductor cross section for main contacts	18 ... 1
AWG number as coded connectable conductor cross section for auxiliary contacts	20 ... 14

Safety related data

product function	
<ul style="list-style-type: none"> • mirror contact according to IEC 60947-4-1 • positively driven operation according to IEC 60947-5-1 • suitable for safety function 	Yes No Yes
suitability for use safety-related switching OFF	Yes
service life maximum	20 a
test wear-related service life necessary	Yes
proportion of dangerous failures	
<ul style="list-style-type: none"> • with low demand rate according to SN 31920 • with high demand rate according to SN 31920 	40 % 73 %
B10 value with high demand rate according to SN 31920	1 000 000
failure rate [FIT] with low demand rate according to SN 31920	100 FIT
ISO 13849	
device type according to ISO 13849-1	3
overdimensioning according to ISO 13849-2 necessary	Yes
IEC 61508	

safety device type according to IEC 61508-2	Type A
Electrical Safety	
protection class IP on the front according to IEC 60529	IP20
touch protection on the front according to IEC 60529	finger-safe, for vertical contact from the front
Communication/ Protocol	
product function bus communication	No
Approvals Certificates	
General Product Approval	



KC



EMV	Test Certificates	Maritime application
-----	-------------------	----------------------



[Special Test Certificate](#)

[Type Test Certificates/Test Report](#)



Maritime application	other	Railway
----------------------	-------	---------



[Confirmation](#)

[Special Test Certificate](#)

Railway	Environment
---------	-------------

[Type Test Certificates/Test Report](#)



[Environmental Confirmations](#)

Further information

Information on the packaging

<https://support.industry.siemens.com/cs/ww/en/view/109813875>

Information for data generation and storage

<https://support.industry.siemens.com/cs/ww/en/view/109995012>

Information- and Downloadcenter (Catalogs, Brochures,...)

<https://www.siemens.com/ic10>

Industry Mall (Online ordering system)

<https://mall.industry.siemens.com/mall/en/en/Catalog/product?mlfb=3RT2038-3XB40-0LA2>

Cax online generator

<https://support.automation.siemens.com/WW/CAXorder/default.aspx?lang=en&mlfb=3RT2038-3XB40-0LA2>

Service&Support (Manuals, Certificates, Characteristics, FAQs,...)

<https://support.industry.siemens.com/cs/ww/en/ps/3RT2038-3XB40-0LA2>

Image database (product images, 2D dimension drawings, 3D models, device circuit diagrams, EPLAN macros, ...)

https://www.automation.siemens.com/bilddb/cax_de.aspx?mlfb=3RT2038-3XB40-0LA2&lang=en

Characteristic: Tripping characteristics, I_t, Let-through current

<https://support.industry.siemens.com/cs/ww/en/ps/3RT2038-3XB40-0LA2/char>

Further characteristics (e.g. electrical endurance, switching frequency)

<https://www.automation.siemens.com/bilddb/index.aspx?view=Search&mlfb=3RT2038-3XB40-0LA2&objecttype=14&gridview=view1>

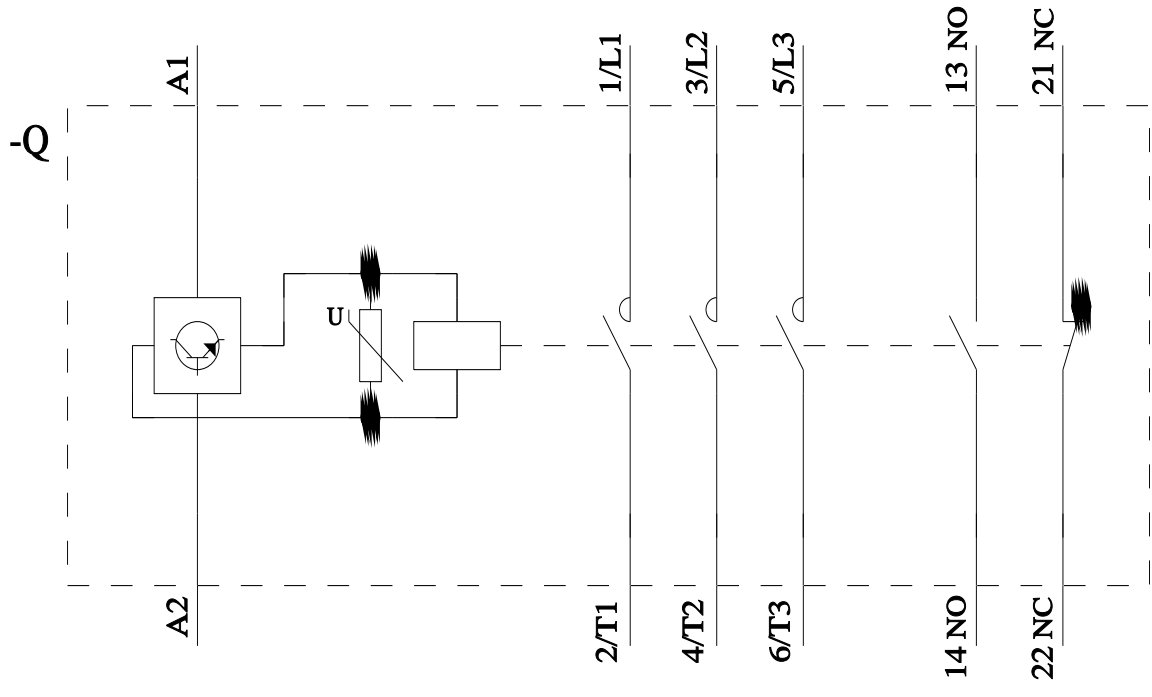
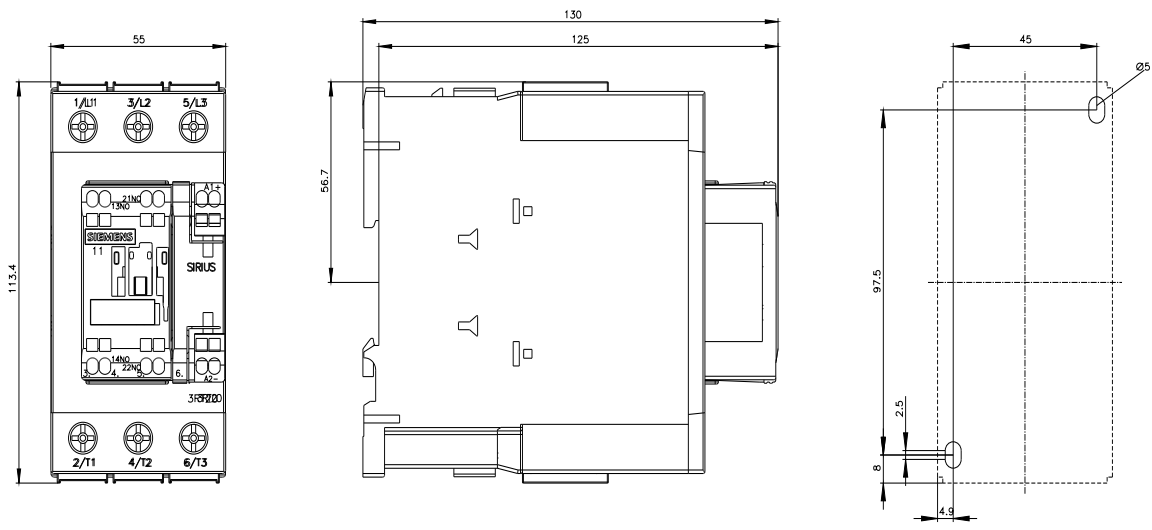

last modified:

11/11/2025

