



contactor relay, 3 NO + 1 NC, 230 V AC, 50/60 Hz, with plugged-on RC element, spring-loaded terminal, frame size S00

<b>product brand name</b>	SIRIUS
<b>product designation</b>	Auxiliary contactor
<b>product type designation</b>	3RH2
<b>General technical data</b>	
<b>size of contactor</b>	S00
product extension auxiliary switch	Yes
power loss [W] for rated value of the current without load current share typical	1.43 W
insulation voltage with degree of pollution 3 at AC rated value	690 V
<b>degree of pollution</b>	3
<b>surge voltage resistance rated value</b>	6 kV
<b>shock resistance at rectangular impulse</b>	
• at AC	7,3g / 5 ms, 4,7g / 10 ms
<b>shock resistance with sine pulse</b>	
• at AC	11,4g / 5 ms, 7,3g / 10 ms
<b>mechanical service life (operating cycles)</b>	
• of contactor typical	30 000 000
• of the contactor with added electronically optimized auxiliary switch block typical	5 000 000
• of the contactor with added auxiliary switch block typical	10 000 000
<b>reference code according to IEC 81346-2</b>	K
<b>Substance Prohibitance (Date)</b>	10/01/2009
<b>SVHC substance name</b>	Lead - 7439-92-1
<b>Weight</b>	0.271 kg
<b>Ambient conditions</b>	
installation altitude at height above sea level maximum	2 000 m
<b>ambient temperature</b>	
• during operation	-25 ... +60 °C
• during storage	-55 ... +80 °C
<b>relative humidity minimum</b>	10 %
<b>relative humidity at 55 °C according to IEC 60068-2-30 maximum</b>	95 %
<b>Environmental footprint</b>	
Environmental Product Declaration (EPD)	Yes
global warming potential [CO <sub>2</sub> eq] total	49.2 kg
global warming potential [CO <sub>2</sub> eq] during manufacturing	1.15 kg
global warming potential [CO <sub>2</sub> eq] during operation	48.2 kg
global warming potential [CO <sub>2</sub> eq] after end of life	-0.139 kg
<b>Main circuit</b>	
<b>no-load switching frequency</b>	
• at AC	10 000 1/h

• at DC	10 000 1/h
<b>Control circuit/ Control</b>	
<b>type of voltage of the control supply voltage</b>	AC
<b>control supply voltage at AC</b>	
• at 50 Hz rated value	230 V
• at 60 Hz rated value	230 V
<b>control supply voltage frequency</b>	
• 1 rated value	50 Hz
• 2 rated value	60 Hz
<b>operating range factor control supply voltage rated value of magnet coil at AC</b>	
• at 50 Hz	0.8 ... 1.1
• at 60 Hz	0.85 ... 1.1
<b>design of the surge suppressor</b>	RC element
<b>apparent pick-up power of magnet coil at AC</b>	37 VA
<b>inductive power factor with closing power of the coil</b>	0.8
<b>apparent holding power of magnet coil at AC</b>	5.7 VA
<b>inductive power factor with the holding power of the coil</b>	0.25
<b>closing delay</b>	
• at AC	8 ... 33 ms
<b>opening delay</b>	
• at AC	4 ... 15 ms
<b>arcing time</b>	10 ... 15 ms
<b>Auxiliary circuit</b>	
<b>number of NC contacts for auxiliary contacts</b>	1
• instantaneous contact	1
<b>number of NO contacts for auxiliary contacts</b>	3
• instantaneous contact	3
<b>identification number and letter for switching elements</b>	31 E
operational current at AC-12 maximum	10 A
<b>operational current at AC-15</b>	
• at 230 V rated value	10 A
• at 400 V rated value	3 A
• at 500 V rated value	2 A
• at 690 V rated value	1 A
<b>operational current at 1 current path at DC-12</b>	
• at 24 V rated value	10 A
• at 110 V rated value	3 A
• at 220 V rated value	1 A
• at 440 V rated value	0.3 A
• at 600 V rated value	0.15 A
<b>operational current with 2 current paths in series at DC-12</b>	
• at 24 V rated value	10 A
• at 60 V rated value	10 A
• at 110 V rated value	4 A
• at 220 V rated value	2 A
• at 440 V rated value	1.3 A
• at 600 V rated value	0.65 A
<b>operational current with 3 current paths in series at DC-12</b>	
• at 24 V rated value	10 A
• at 60 V rated value	10 A
• at 110 V rated value	10 A
• at 220 V rated value	3.6 A
• at 440 V rated value	2.5 A
• at 600 V rated value	1.8 A
<b>operating frequency at DC-12 maximum</b>	1 000 1/h
<b>operational current at 1 current path at DC-13</b>	
• at 24 V rated value	10 A
• at 110 V rated value	1 A
• at 220 V rated value	0.3 A
• at 440 V rated value	0.14 A

<ul style="list-style-type: none"> <li>at 600 V rated value</li> </ul>	0.1 A
<b>operational current with 2 current paths in series at DC-13</b>	
<ul style="list-style-type: none"> <li>at 24 V rated value</li> <li>at 60 V rated value</li> <li>at 110 V rated value</li> <li>at 220 V rated value</li> <li>at 440 V rated value</li> <li>at 600 V rated value</li> </ul>	10 A 3.5 A 1.3 A 0.9 A 0.2 A 0.1 A
<b>operational current with 3 current paths in series at DC-13</b>	
<ul style="list-style-type: none"> <li>at 24 V rated value</li> <li>at 60 V rated value</li> <li>at 110 V rated value</li> <li>at 220 V rated value</li> <li>at 440 V rated value</li> <li>at 600 V rated value</li> </ul>	10 A 4.7 A 3 A 1.2 A 0.5 A 0.26 A
<b>operating frequency at DC-13 maximum</b>	1 000 1/h
<b>contact reliability of auxiliary contacts</b>	1 faulty switching per 100 million (17 V, 1 mA)
<b>UL/CSA ratings</b>	
<b>contact rating of auxiliary contacts according to UL</b>	A600 / Q600
<b>Short-circuit protection</b>	
design of the miniature circuit breaker for short-circuit protection of the auxiliary circuit up to 230 V	C characteristic: 10 A; 0.4 kA
design of the fuse link for short-circuit protection of the auxiliary switch required	gG: 10 A (690 V, 1 kA)
<b>Installation/ mounting/ dimensions</b>	
<b>mounting position</b>	+/-180° rotation possible on vertical mounting surface; can be tilted forward and backward by +/- 22.5° on vertical mounting surface
<b>fastening method</b>	screw and snap-on mounting onto 35 mm DIN rail
<b>height</b>	70 mm
<b>width</b>	45 mm
<b>depth</b>	121 mm
<b>required spacing</b>	
<ul style="list-style-type: none"> <li>with side-by-side mounting               <ul style="list-style-type: none"> <li>forwards</li> <li>upwards</li> <li>downwards</li> <li>at the side</li> </ul> </li> <li>for grounded parts               <ul style="list-style-type: none"> <li>forwards</li> <li>upwards</li> <li>at the side</li> <li>downwards</li> </ul> </li> <li>for live parts               <ul style="list-style-type: none"> <li>forwards</li> <li>upwards</li> <li>downwards</li> <li>at the side</li> </ul> </li> </ul>	10 mm 10 mm 10 mm 0 mm  10 mm 10 mm 6 mm 10 mm  10 mm 10 mm 10 mm 6 mm
<b>Connections/ Terminals</b>	
type of electrical connection for auxiliary and control circuit	spring-loaded terminals
<b>type of connectable conductor cross-sections</b>	
<ul style="list-style-type: none"> <li>for auxiliary contacts               <ul style="list-style-type: none"> <li>solid or stranded</li> <li>finely stranded with core end processing</li> <li>finely stranded without core end processing</li> </ul> </li> <li>for AWG cables for auxiliary contacts</li> </ul>	2x (0,5 ... 4 mm <sup>2</sup> ) 2x (0.5 ... 2.5 mm <sup>2</sup> ) 2x (0.5 ... 2.5 mm <sup>2</sup> ) 2x (20 ... 12)
<b>Safety related data</b>	
<b>product function</b>	
<ul style="list-style-type: none"> <li>positively driven operation according to IEC 60947-5-1</li> <li>suitable for safety function</li> </ul>	Yes Yes
suitability for use safety-related switching OFF	Yes
<b>service life maximum</b>	20 a

<b>proportion of dangerous failures</b>	
<ul style="list-style-type: none"> <li>with low demand rate according to SN 31920</li> <li>with high demand rate according to SN 31920</li> </ul>	<p>40 %</p> <p>73 %</p>
<b>B10 value with high demand rate according to SN 31920</b>	1 000 000; With 0.3 x I <sub>e</sub>
<b>failure rate [FIT] with low demand rate according to SN 31920</b>	100 FIT
ISO 13849	
<b>device type according to ISO 13849-1</b>	3
<b>overdimensioning according to ISO 13849-2 necessary</b>	Yes
IEC 61508	
<b>safety device type according to IEC 61508-2</b>	Type A
Electrical Safety	
<b>protection class IP on the front according to IEC 60529</b>	IP20
<b>touch protection on the front according to IEC 60529</b>	finger-safe, for vertical contact from the front
<b>Approvals Certificates</b>	
General Product Approval	



KC



EMV	Functional Safety	Test Certificates	Maritime application
-----	-------------------	-------------------	----------------------



[Type Examination Certificate](#)

[Special Test Certificate](#)

[Type Test Certificates/Test Report](#)



Maritime application	other
----------------------	-------



Miscellaneous



other	Railway	Environment
-------	---------	-------------

[Confirmation](#)

[Special Test Certificate](#)



[Environmental Confirmations](#)

### Further information

Information on the packaging

<https://support.industry.siemens.com/cs/ww/en/view/109813875>

Information for data generation and storage

<https://support.industry.siemens.com/cs/ww/en/view/109995012>

Information- and Downloadcenter (Catalogs, Brochures,...)

<https://www.siemens.com/ic10>

Industry Mall (Online ordering system)

<https://mall.industry.siemens.com/mall/en/en/Catalog/product?mlfb=3RH2131-2EP00>

Cax online generator

<https://support.automation.siemens.com/WW/CAXorder/default.aspx?lang=en&mlfb=3RH2131-2EP00>

Service&Support (Manuals, Certificates, Characteristics, FAQs,...)

<https://support.industry.siemens.com/cs/ww/en/ps/3RH2131-2EP00>

Image database (product images, 2D dimension drawings, 3D models, device circuit diagrams, EPLAN macros, ...)

[https://www.automation.siemens.com/bilddb/cax\\_de.aspx?mlfb=3RH2131-2EP00&lang=en](https://www.automation.siemens.com/bilddb/cax_de.aspx?mlfb=3RH2131-2EP00&lang=en)

Characteristic: Tripping characteristics, I<sup>2</sup>t, Let-through current

<https://support.industry.siemens.com/cs/ww/en/ps/3RH2131-2EP00/char>

Further characteristics (e.g. electrical endurance, switching frequency)

<https://www.automation.siemens.com/bilddb/index.aspx?view=Search&mlfb=3RH2131-2EP00&objecttype=14&gridview=view1>

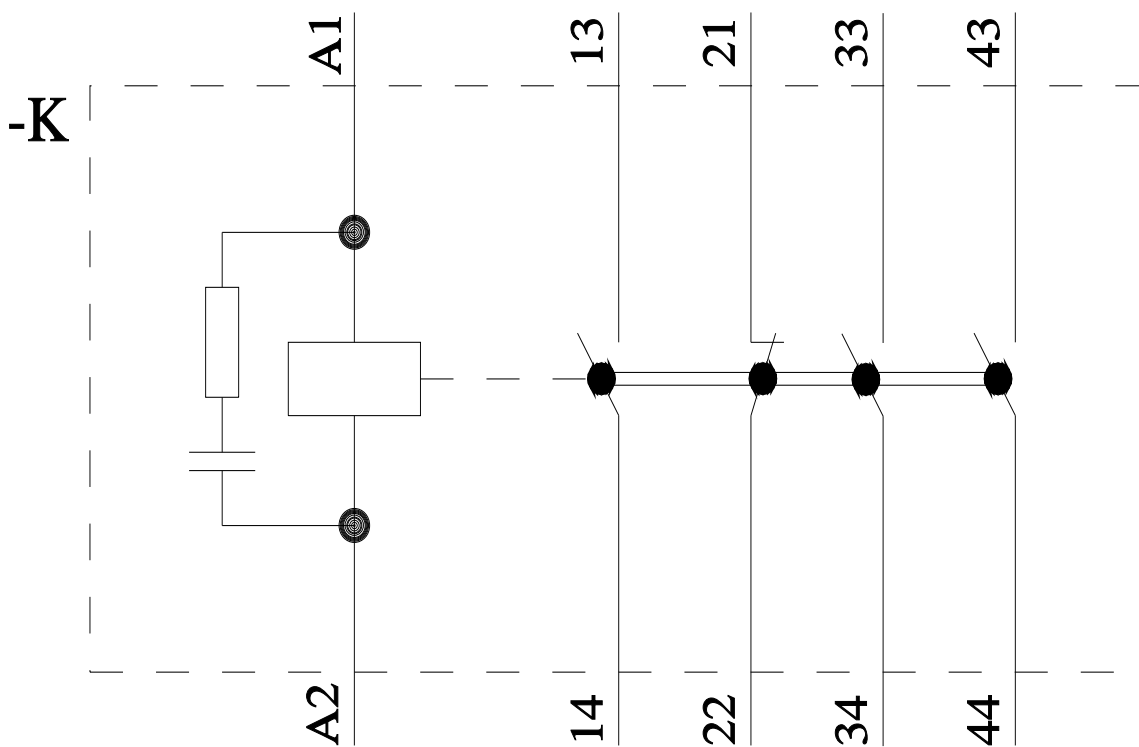
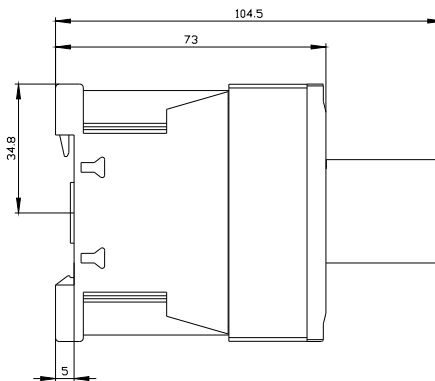
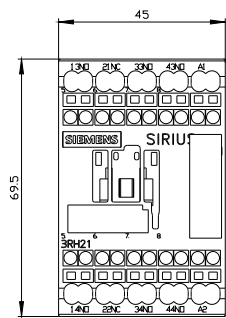

last modified:

9/5/2025